

HCL. Column level indicators

with U shaped protection, technopolymer



ASSEMBLY ENDS
Glass-fibre reinforced polyamide based (PA) technopolymer, black colour.



SUPPORT
Aluminium in natural colour. It can be turned by 90°C where necessary.



LEVEL COLUMN WINDOW
Polymethylmethacrylate transparent tube.



SCREWS
Zinc-plated steel with hexagon socket.



PACKING RINGS
NBR synthetic rubber O-Ring.



GRADUATED CONTRAST SCREEN
Plastic material, resistant to oils and greases. Fitted to the aluminium protection by means of an adhesive tape.



MAXIMUM CONTINUOUS WORKING TEMPERATURE
70°C (with oil or water).



TECHNICAL DATA
In laboratory tests carried out with mineral oil type CB68 (according to ISO 3498) at 23°C for a limited period of time, the weld stood up to: 30 bar (HCL.300), 25 bar (HCL.400) and 20 bar (HCL.500).
For use with other fluids and under different pressure and temperature conditions, please contact ELESA Technical Department.
In any case we suggest to verify the suitability of the product under the actual working conditions.



- SPECIAL EXECUTIONS ON REQUEST**
- Column level indicators with tubes and assembly ends in different materials for the use with special fluids and/or at high temperatures.
 - AISI 316 stainless steel or nickel-plated brass screws.
 - Polyamide based (PA) technopolymer float, red colour to highlight the level also from a long distance.
 - Column level indicators with fitting centre-holes up to 2000 mm.
 - HCL-E column oil level indicators including float, minimum level signal, normally closed contacts (NC), normally open (NO) or CHANGE OVER.
 - Adjustable level sensors which can be placed along the axis of the indicator, with right (DX) or left (SX) connectors, normally closed (NC), normally open (NO) or CHANGE OVER contacts.
 - EPDM or FKM type VITON®* packing rings.

* Registered trademark by DuPont Dow Elastomers.



Drilling template
Holes without burrs and chamfer

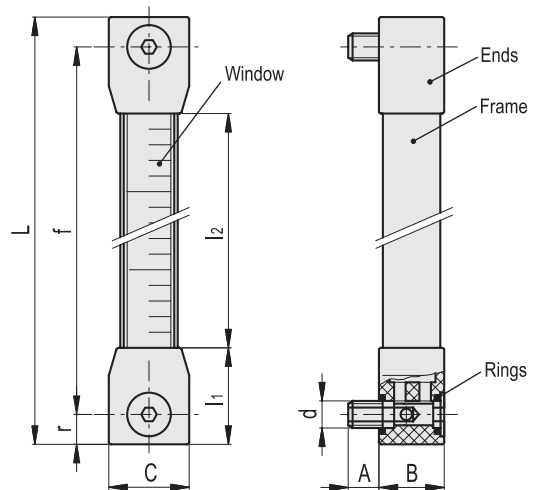
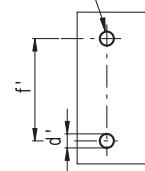

Accessories for hydraulic systems

Conversion Table	
1 mm = 0.039 inch	
f	
mm	inch
300	11.81
400	15.75
500	19.69



Code	Description	f	d	A	B	C	L	l1	l2	r	d ^{±0.2}	f ^{±0.2}	C# [Nm]	⚖
111211	HCL-300-M12	300	M12	13.5	28.5	35	326	42	242	13	12.5	300	15	227
111221	HCL-400-M12	400	M12	13.5	28.5	35	426	42	342	13	12.5	400	15	268
111231	HCL-500-M12	500	M12	13.5	28.5	35	526	42	442	13	12.5	500	15	306

1612 # Maximum tightening torque.